

Connecting your E110

When buying a load cell with an E110 signal conditioner, there are two main interfaces to connect it to your instrumentation

Analog Output

This mode of operation is to read an analog voltage from an E110 signal conditioner board.

The analog output's voltage range will be between 0 and 5v.

The power supply must output between 5v and 24v

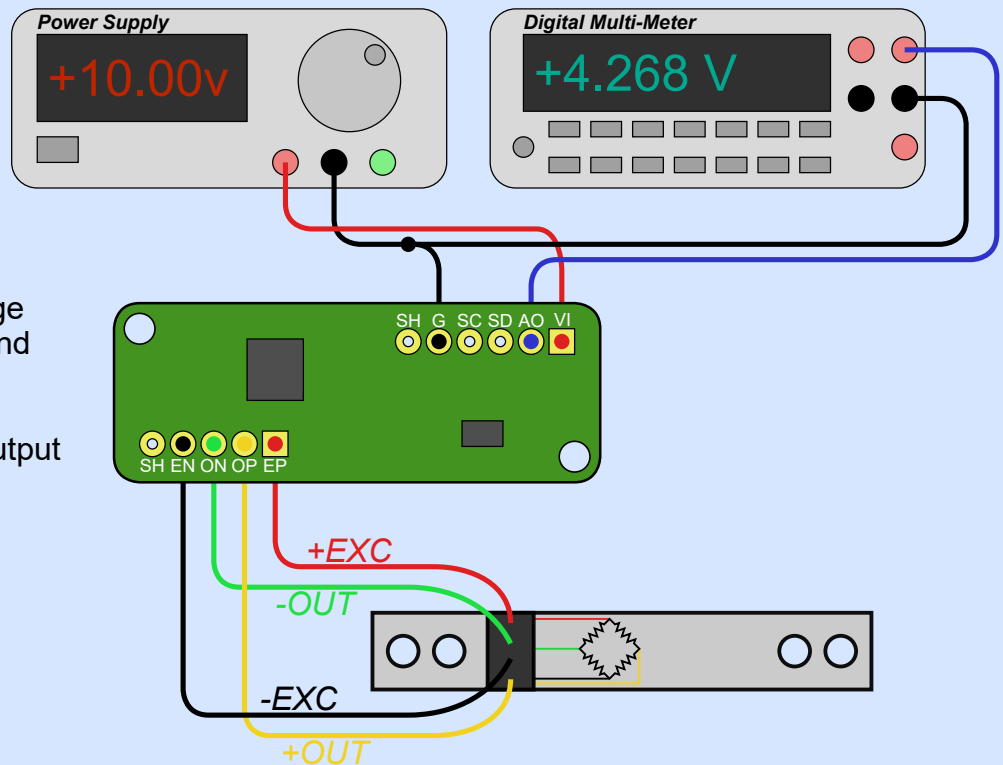

Digital Output

This mode of operation is to read a digital 16-bit output from the E110.

The interface uses the I2C protocol, which can be connected to any microcontroller, such as an Arduino shown here.

Two 4.7kΩ pull-up resistors must be connected between Vin and SDA, and Vin and SCL. This can be done with a breadboard.

To read a sample from the E110, simply initialize an I2C read transaction for 2 bytes, which are the 15-bit readout from the signal conditioner. An example transaction diagram is shown below

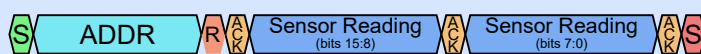

Example Arduino code can also be found on our website.

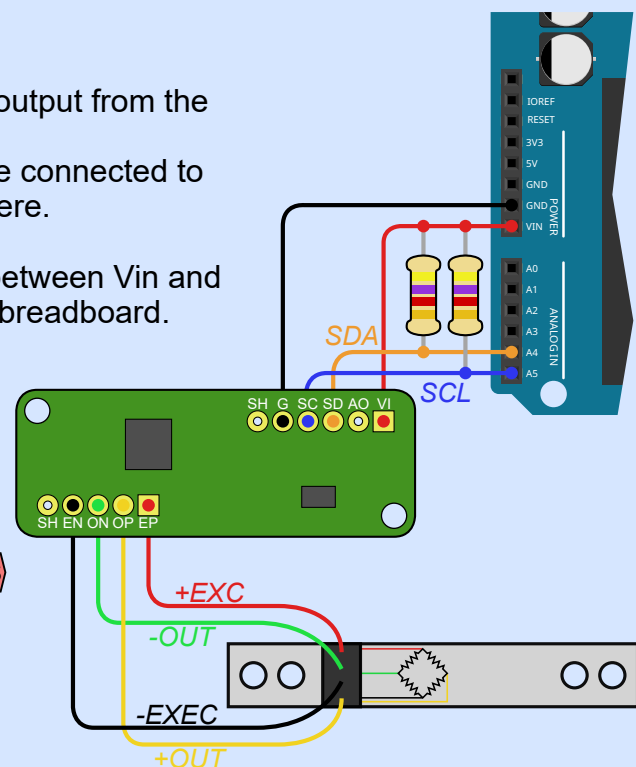

Additional Notes:

- Strain Gauge wire color may vary per part, refer to your part's datasheet for correct wire color
- Load cell shown is an S100. Your load cell may visually differ